

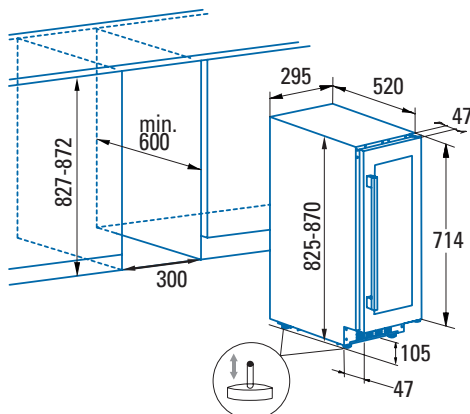

VI 30117 X
Cod. **07751007** EAN **8422248101806**



- No frost built-in wine cooler
- Capacity **17 bottles**
- Dual Temperature zone between 5/22°C**
5/13° for white without oak-aging period, sweet, rosé and champagne
13/22° for white with oak-aging, red
- Electronic temperature control**
- Digital touch control panel**
- Inner led light**
- Reversible door
- Inner ventilation for quick cooling
- Energy class G
- Climatic class SN/N/ST (10-38°)
- Sound level 41dB
- Energy consumption 137 kWh/year
- Nominal power 80W
- 220-240V 50Hz



Code	07751007
EAN	8422248101806
Model	VI 30117 X
Finish	Stainless Steel
Product fiche according to EU Regulation 1060/2010	
Category	Compressor wine cooler
Energy efficiency class	G
Energy consumption [kWh/year]	137
Refrigerator storage volume [l]	52
Climatic class	SN/N/ST
Noise emissions [dBA]	41
Installation type	Built-in
Technical specs and control type	
Refrigerator system	Compressor
Display	Touch control display on the door
Wine cooler lighting	Led
Temperature zones	2
Temperature ranges (°C)	5-22
Storage levels	5
Capacity (bottles)	17
Opening of the door	Right
Reversible doors	Yes
Adjustable feet	Yes
Dimensions	
Height [mm]	825-870
Width [mm]	295
Depth [mm]	520
Cabinet dimensions	
Minimum cabinet height [mm]	827-872
Minimum cabinet width [mm]	300
Minimum cabinet depth [mm]	600
Power connection	
Voltage range [V]	220-240
Frequency [Hz]	50
Rated power [W]	80
Type of plug	Schuko
Power cord length [mm]	1500